I-BUS Inside

Inside the BMW Cars entertainment Serial Bus

Written by Franck Touanen.
HackIBus@Yahoo.fr

2002, December.
Version DRAFT. REV 5.

Introduction and warning	4
Bus in automotive applications.....	5
I-Bus General Architecture	7
I-Bus Messages.....	8
Typicals Device IDs	8
I-Bus Packet Structure.....	9
Hardware to read/write I-BUS	10
Basic Interface	10
Contention Detection Interface	11
Melexis Chip Interface	11
I-BUS Analyser software	12
The I-Bus Analyser Software. (V1.00)	12
Steering Wheel Messages	17
Messages to Radio (68H).....	17
Messages to Telephone (C8H).....	17
Instrument Control Messages (IKE).....	18
Messages to OBC Text (E7H).....	18
Board Monitor Buttons (Nav system)	20
Messages to Radio (68H).....	20
Messages to Navigation / Video (3BH).....	21
Broadcast Messages (FFH).....	21
RADIO Messages	22
Messages to Navigation / Video (3BH).....	22
Messages to Instrument Control Electronics – IKE (80H).....	25
Messages to CD Player (18H).....	25

CD PLAYER Messages	27
CD Player behaviour	27
Broadcast Messages (FFH).....	27
Messages to Radio (68H).....	27
Navigation / Vidéo module Messages.....	28
Messages to IKE (80H)	28



Introduction and warning

A part of this information is based on research done by Thomas L. Wood, who has connected a Linux embedded PC in his E39 (without NAV) to play MP3 . After exchanges with Thomas, I built my own interface to start I-Bus analysis with the objective to interface a MP3 pic based player fully integrated with the board monitor.

Note that all this document is based on analysis done in a E39 (July 2000) with a MK II navigation system. I can't ensure if informations and/or device behaviours are identical for others models.

DISCLAIMER :

I'm not related in any way with BMW AG or any of its subsidiaries. All trademarks are property of their respective owners. Any copyrighted information in this document belonging to third parties is presented for non-commercial purposes only and purely for sake of education, scholarly analysis or criticism under the Fair Useage terms of copyright law.

This document is unofficial and informations it contains can cause some problems to your car if you don't know what your are doing, and I suppose, could cancel the Guarantee. **USE THIS AT YOUR OWN RISK.** I disclaim anything.

This document is free ; you can redistribute it and/or modify it under the terms of the GNU General Public License as published by the Free Software Foundation; either version 2 of the License, or (at your option) any later version.

This document is distributed in the hope that it will be useful, but **WITHOUT ANY WARRANTY**; without even the implied warranty of **MERCHANTABILITY** or **FITNESS FOR A PARTICULAR PURPOSE**. See the GNU General Public License for more details.

You should have received a copy of the GNU General Public License along with this document; if not, write to the Free Software Foundation, Inc., 59 Temple Place, Suite 330, Boston, MA 02111-1307 USA

If you find errors or missing things, you can mail me at HackIBus@yahoo.fr.

Bus in automotive applications

A bus is basically a shared communication link.

It's a collection of wires through which data is transmitted from one part of a computer to another. You can think of a bus as a highway on which data travels within a computer.

In your computer, you can find e.g. a PCI bus to establish communication between extension cards and the CPU, the memory bus, the AGP bus for video, the Universal Serial Bus for high speed serial devices ...

In your BMW, a bus is used to establish communication between security equipments, for engine control, or for entertainment devices (the famous IBus).

In automotive application, 2 mains bus architecture are used (others are often derivated from) :

The CAN bus and the LIN bus.

CAN Bus (Controller Area Network)

The CAN Bus was developed by Robert Bosch, GmbH. It combines extensive error checking with a high data throughput to create an extremely powerful platform for local communication. CAN has an event driven, priority based protocol which means that any device may attempt to communicate on the bus, but priority is given to the node with a greater priority "message identifier".

Physically the CAN system is based around a single twisted pair of conductors, but can be realised on a number of mediums, including single wire and fibre optic. This configuration is quite robust and allows for 1 wire to be broken, shorted to ground or shorted to power (with reduced signal to noise).

Currently CAN is very popular in Germany (it's country of origin) and in Europe, but has not penetrated many other markets effectively. However, it is predicted that by the year 2002 US car manufacturers will be using CAN in volume.

LIN Bus (Local Interconnect Network)

LIN is a relatively new bus. It was developed through the collaboration of several companies, namely; Audi, BMW, Daimler-Chrysler, Motorola GmbH, Volcano Communications Technologies, Volvo and Volkswagen.

LIN is based on the ISO 9141 specification. The network layout of the system uses a single wire 12V bus, one master and several slave nodes. The slave nodes have no knowledge of the other nodes on the network except the master node, and the master node controls communication on the bus. LIN is optimal for applications such as doors, steering wheels, seats, climate regulation, lighting, rain sensors, or alternators.

The LIN protocol was not designed to be a competitor to the controller area network (CAN) protocol or other high level system. It aims at applications that don't require the flexibility and data rate of CAN. Thus it is possible for the two systems to be implemented in the one vehicle, and even for the LIN and CAN networks to share data through a gateway. LIN is designed for use in applications that will provide enhanced features in the automobile, but where the cost of using CAN implementations is prohibitive. See diagram below.

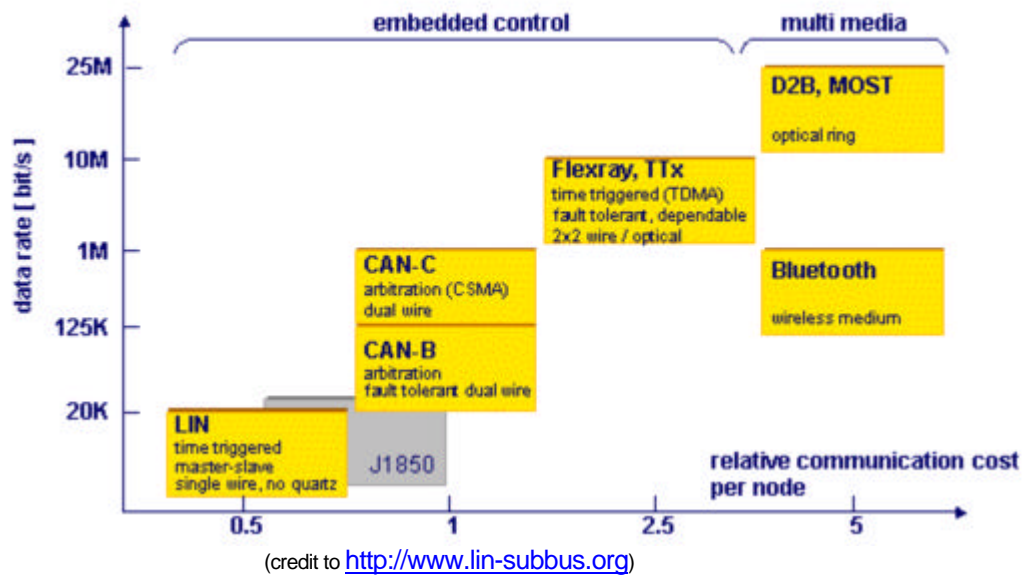

The LIN Consortium has grown beyond just the seven members of the steering circle to include over 20 companies worldwide, including most major automotive OEMs. LIN is already being implemented on cars in Europe. According to the LIN Consortium, the number of LIN nodes is expected to rapidly grow over the next decade to an average of twenty per vehicle, or a worldwide volume of approximately 1.2 billion LIN nodes per year.

I-Bus General Architecture

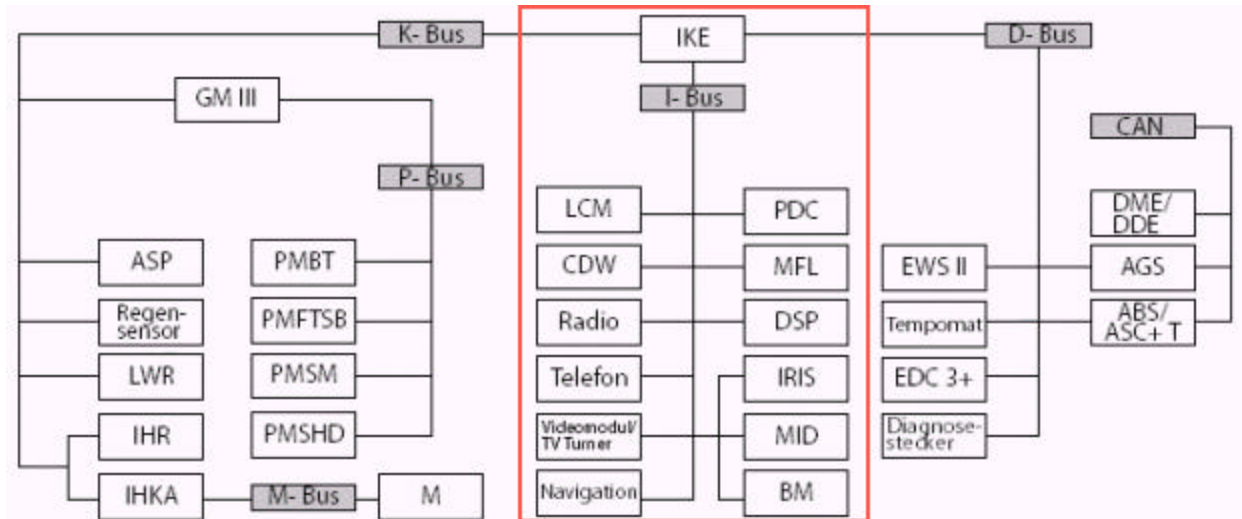

(Credit to www.openbmw.org for figure and a part of the following explanation)

The I-BUS, as you can see on the figure, handles "multimedia" on-board peripherals. It is absolutely not linked to some security equipments, like airbags, ASP, AGS (so hacking will not hurt you...).

BMW's I-Bus is based on ISO 9141 and K-Bus, a bus largely used in automotive application. It is basically a second K-Bus in the car for handling interfacing between the radio, CD, navigation, and telephone systems, or any other system. In particular, the steering wheel controls for the radio utilize the I-Bus.

The I-Bus is a single wire bus. That means it uses only one wire to send and receive data.

In the car you can find the I-BUS wire at the CD changer connector in the rear, the Navigation system CD-ROM unit connector, the phone connector in the center console, etc.

It's a white/red/yellow wire (see picture below)

<IBUS PHOTO CD + NAV Sys >

You can see the RJ connector (telephone type with 4 pins) I have soldered to the Ibus for a clean and chip connection.

The bus' physical layer is an open collector setup pulled high (+12v) by the bus, and pulled low by the talker. This means that the normal voltage on the wire is +12v (the battery voltage, or V_{batt}).

A bit is transmitted by pulling low or shorting the bus with the ground momentarily. This is the reverse of many digital signals where the normal voltage is 0v and is raised high (V_{max} which in this case is V_{batt} or +12v) to send a bit.

Serial communications on the bus are 9600 bps, 8 data bits, Even parity, 1 stop bit.

I-Bus Messages

Typicals Device IDs

In the system, each device is identified by a unique code, 1 byte length.

Id	Device name
00	Broadcast
18	CDW - CDC CD-Player
30	?????
3B	NAV Navigation/Videomodule
3F	?????
43	MenuScreen
44	?????
50	MFL Multi Functional Steering Wheel Buttons
60	PDC Park Distance Control
68	RAD Radio
6A	DSP Digital Sound Processor
7F	?????
80	IKE Instrument Kombi Electronics
A8	?????
BB	TV Module
BF	LCM Light Control Module
C0	MID Multi-Information Display Buttons
C8	TEL Telephone
D0	Navigation Location
E7	OBC TextBar
E8	?????
ED	Lights, Wipers, Seat Memory
F0	BMB Board Monitor Buttons
FF	Broadcast

I-Bus Packet Structure

The structure of an Ibus packet is the following :

- *Source Device ID*
The device which needs to send a message to another device
- *Length*
The length of the packet without Source ID and length it-self.
- *Destination Device ID*
The device which must receive the message
- *Data*
The message to send to Destination ID
- *XOR CheckSum*
This byte is used to check the integrity of the message. The receiver will compare that value with its own computation, and if not equal, will reject the packet.



The Xor checksum is a XOR byte per byte for all bytes contained in the packet.
The Xor checksum must be set to 00H before the computation.

Hardware to read/write I-BUS

Basic Interface

Small is beautiful. Do not detect contention, but who cares ?

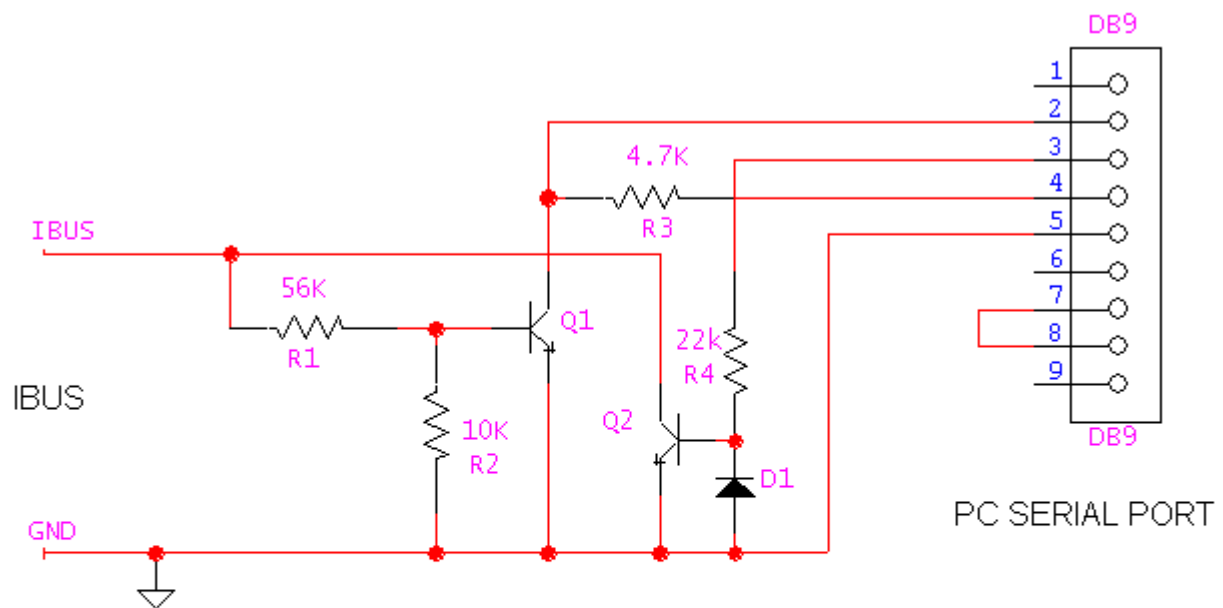

Q1,Q2 Generic NPN transistor e.g. 2N2222, 2N3904 etc

D1 Generic silicon diode e.g. 1N4148, 1N914

Q2, D1 and R4 only needed for transmit

Title IBUS Interface
Date 01/31/03
Kevin White

Contention Detection Interface

Thomas L. Wood has built a specific circuit, with a contention detection system, mainly based on a RS latch, and a MAX232A.

The MAX232A CI from Maxim converts RS232 levels (-12V, +12V) from a PC to TTL levels (0V, +5V). The rest of the circuit is built with classical logical gates (74HC27, 74HC08, 74HC04). Note that 74LS type are also working even if they are slower.

To use this circuit, the software must first assert the RTS line, and wait to get the CTS line before sending a message. If you loose CTS right after sending your message, there was a contention. If your message has been sent, check it in the receive buffer. You must get the echo.

Just for delay : at 9600 Bauds, send one byte take about 1 ms.

You can find the PDF file for the schematic here :

http://autos.groups.yahoo.com/group/HackTheIBus/files/IBUS%20Interfaces/232TOOC_REV1.pdf

Melexis Chip Interface

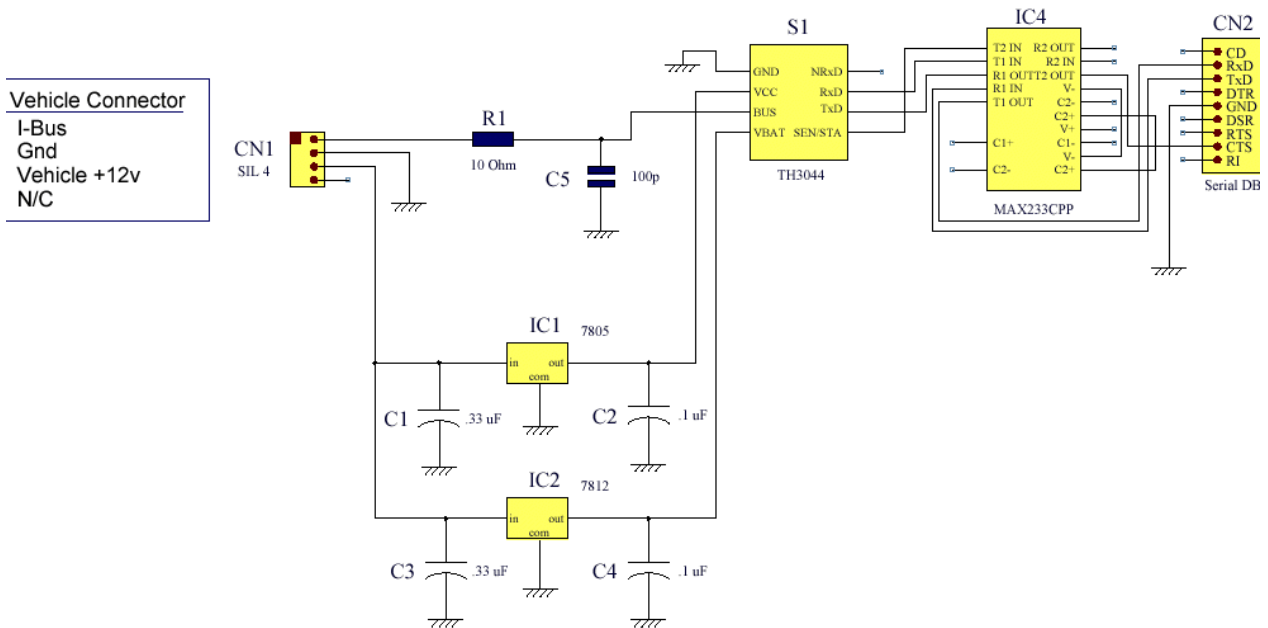

The contention is detected by the chip itself. If the CTS is low, then there is some traffic on the BUS.

I-BUS Analyser software

The I-Bus Analyser Software. (V1.00)

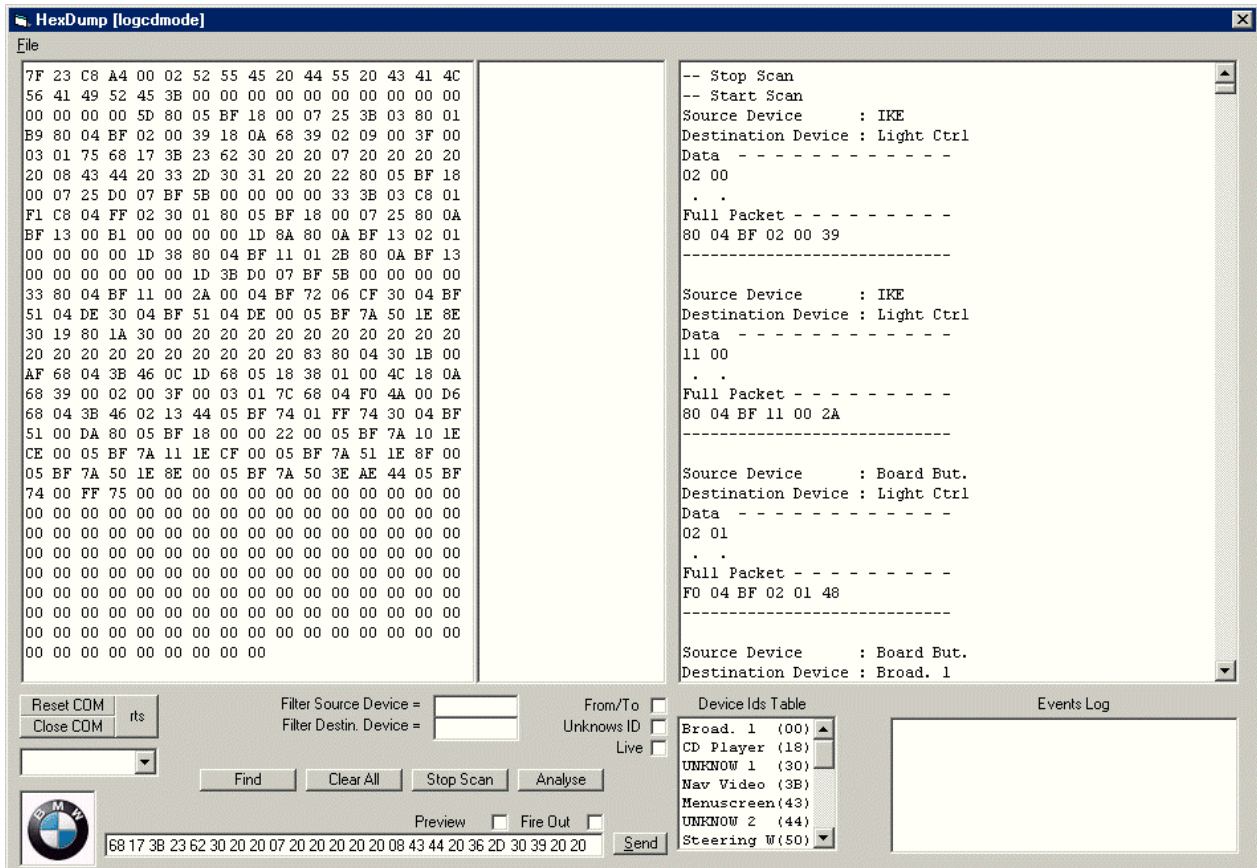

The I-Bus software analyser allows you to display I-BUS messages in clear text for everybody understanding. You have the choice to scan in real time the COM PORT and I-BUS conversations, to load a binary (.bin), an hexa file, or copy and paste to the hexa area some hexa bytes from a dump window in another software. A big part of my analysis of Ibus messages was done with that software.

Menu "FILE"

Open : Open a binary file or an hexa bytes file. Note that the binary file must be a ".bin" type to be interpreted as is. Hexa bytes can be text files or RTF with colors.

Save : Save the hexa text box to a file. This allows you to save a log from COM port as a text file.

"RTS/rts" button

This button enables or disable RTS. If RTS is enable, the button caption is "RTS" in uppercase letters, else it's "rts". If the text "(1)" appears after the rts/RTS text, that means you hold CTS : you can transmit because it's Clear To Send.

"Reset COM" button

This will reset (close and reopen) the current COM port. If you have some trouble to communicate with I-BUS, it can help.

"Close COM" button

This will simply close the COM port you were using for IBA.
The "Start Scan" button will automatically re-open the port.
This is usefull is you are using another software on the same serial port.

"Stop Scan / Start Scan" button

This button will stop/start to dump bytes from the COM port.
The "Stop Scan" will not close the communication.

If you let your PC running IBA, the log can grow dramatically. The scan mode reduce it self the size to 10% every 30 000 bytes to avoid memory (and windows) crash.

"Clear All" button

This will clear all windows : hexa bytes, ascii , analysed bytes, log windows.

"Find" button

This will hightlighth some hexa string you want to search in the hexa windows.

"Analyse" button

This will start the message analysis. The analyser will display clear text message description in the right part of the main window. You can copy and paste results to another software like a text editor.

Analyser options

Filtering packets:

You can use "Filter Source Device", and/or destination device fields. You can enter many devices ID, separated by a comma. e.g. "68,3B" or only one.

e.g. : If you want to see only packet sent by the radio, enter 68 in the "Src id" field then click on "Analyse".

The "FROM/TO" check box allows you to filter only message from and to a specific device.

e.g. If you want to see every packet FROM/TO the CD Player, enter "18" in the "Filter Source Device" field, check "FROM/TO" checkbox then click on the "Analyse" button. This will show you a diagram like the following :

```
Source Device      : CD Player
Destination Device : Broad. 2
Data  - - - - -
02 01
```

```
Full Packet - - - - -
18 04 FF 02 01 E0
-----
```

```
<---Source Device      : Radio
<---Destination Device : CD Player
<---Data  - - - - -
<---Poll CD Player
```

```
<---Full Packet - - - - -
<---68 03 18 01 72
<-----
```

Unknow devices ID

As we didn't guess (not yet !) what are all devices ID, by checking this option , the analyser will assume that every bytes from 00 to FFH can be a valid device ID. This will avoid sometimes a great numbers or errors when decoding.

Note : The error counter is the number of byte the analyser couldn't decode as belonging to a valid message.

Live Mode :

The live mode is not a really "live" analyser. It's just activating a 1 seconde timer triggering the "Analyse" button. Only the the last 1000 bytes of the log are taken in consideration. The useful point, is that it will synchronize the "virtual" navigation screen (see below).

"Send" button

The Send text box is used to send message you enter directly in hexadecimal value in the input box on the left side of the button. The message must be a valid IBUS message, but the checksum is computed automatically : DO NOT ADD THE CHECKSUM BYTE. IBA will add it !!

The len of the message is also automatically computed. Simply enter 00 just to let room for the right len in the message whren sending.

You can also send TEXT by using quotes. Only one text string can be sent.

e.g.

-> 68 00 18 01
Will poll the CD player

-> 68 00 3B 23 62 30 'Hello World'
Will display Hello world to the area 0 of the nav screen.

The log is updated each time you send something in the hexa dump window.

Preview

The preview check box is used to see the message before sending it (e.g. get the checksum and len).

Fire Out

If you want to send a message every second, without having to click each time on the "Send" button, just use "Fire Out". It's usefull for testing circuits, POLL Messages, or to stress a device for simulating bus traffic.

Button Board Emulator.

To get the BMB emulator, click on the BMW logo (you will get also the NAV Screen emulator).

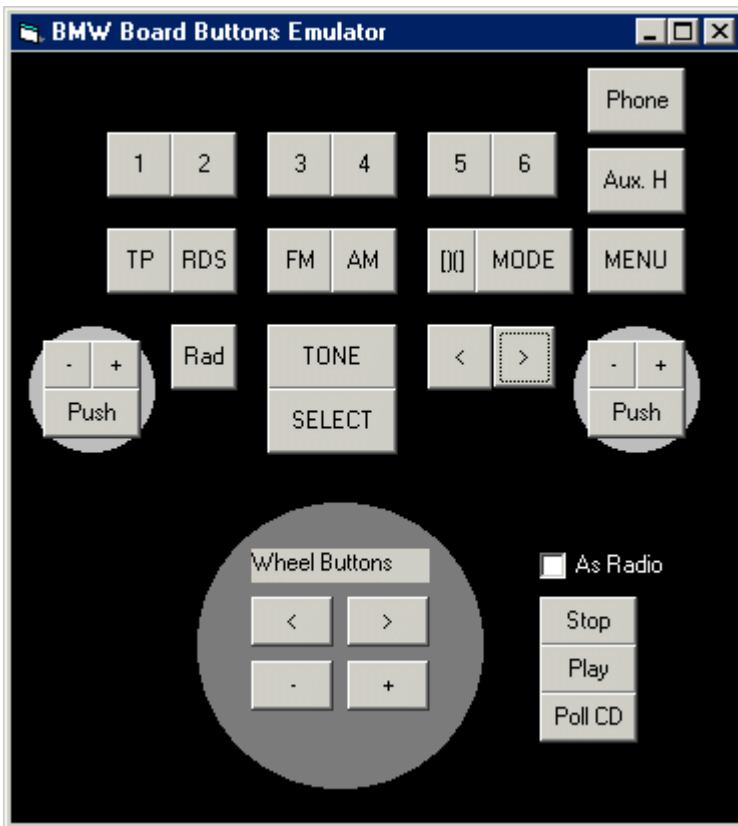

You can use buttons exactly as you use BMB in your car. The release event is simulated.

If you check the "As Radio" box, this will simulate order sent by the radio to the CD player instead of sending BMB events. e.g. If you click on the "1" button, that will send "Play CD#1", and not "BMB Button 1".

Nav Video Messages Sender and Emulator



To get the NAV emulator screen, click on the BMW logo (you will get also the BMB emulator).
(TO BE CONTINUED....)

Steering Wheel Messages

DEVICE ID = 50H

The cruise control buttons messages are not seen on the I-Bus.
Only audio and telephone buttons send messages.

Messages to Radio (68H)

Button "-" (Volume Down)

32 10

Button "+" (Volume Up)

32 11

Button ">" (Next Track)

3B 01 Push 3B 21 Release

Button "<" (Previous Track)

3B 08 Push 3B 28 Release

Messages to Telephone (C8H)

Dial Number Button

3B 80 Push 3B A0 Release

Button "R/T"

3B 40

Instrument Kombi Messages (IKE)

DEVICE ID = 80H

Send (urgent ?) Message to OBC Text

1A 35 00 <Text>

```

Source Device      : (Unknow ID =30)
Destination Device : IKE
Data Len (Checksum): (83)
Data - - - - -
1A 35 00 20 20 43 48 45 43 4B 20 43 4F 4E 54 52 4F 4C 20 4F 4B 20 20
. 5 .          C H E C K          C O N T R O L          O K
Full Packet - - - - -
30 19 80 1A 35 00 20 20 43 48 45 43 4B 20 43 4F 4E 54 52 4F 4C 20 4F 4B 20 20 83
-----
    
```

Messages to OBC Text (E7H)

Set OBC Text Parameter

24 nn 00 <Text>

Where nn is the parameter identifier :

Nn	Parameter	Sample Text
01	Time	" 9:50 "
02	Date	"19.11.2002"
03	Out. Temp.	" +6.5.C"
04	Consumption 1	"9.4 L/100"
05	Consumption 1	"9.4 L/100"
06	Range	"541 KM "
07	Distance	"- 405 KM"
08		"--:-- "
09	Limit	"170 KM/H"
0A	Average Speed	"50.7 KM/H"
0E	Timer	" 0.0 SEC"
0F	Aux.Heating Timer 1	"--:-- "
10	Aux.Heating Timer 2	"--:-- "
1A		" 0.0 SEC"

OBC Parameter table

Backward signal. Used for retrovisors auto moving.

80 0A BF 13 00 13 00 00 00 00 20

Speed Signal

80 05 BF 18 06 0E Display security Message on the TV screen

80 05 BF 18 00 07 Nothing displayed (the car is running lower than 5 KM/H)

I have tried to fire the previous message every seconds running in my car, and the TV was working 1 second then I get the message 1 second, then again TV...and so on. (Use the FIRE option of the IBA software)

Board Monitor Buttons (Nav system)

DEVICE ID = F0H

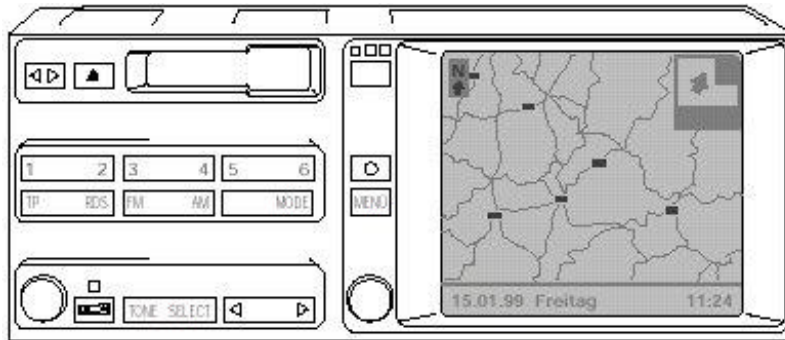

Messages to Radio (68H)

Button Label	Push Message	Push More 1 Second	Release Message	Button Label	Push Message	Push More 1 Second	Release Message
<> (Reverse Tape)	48 14	48 54	48 94	▲ (Eject Tape)	48 24	48 64	48 A4
1	48 11	48 51	48 91	2	48 01	48 41	48 81
3	48 12	48 52	48 92	4	48 02	48 42	48 82
5	48 13	48 53	48 93	6	48 03	48 43	48 83
TP	48 32	48 72	48 B2	RDS	48 22	48 62	48 A2
FM	48 31	48 71	48 B1	AM	48 21	48 61	48 A1
(Dolby)	48 33	48 73	48 B3	MODE	48 23	48 63	48 A3
TONE	48 04	48 44	48 84	SELECT	48 20	48 60	48 A0
< (Previous Track)	48 10	48 50	48 90	> (Next Track)	48 00	48 40	48 80
(radio menu)	48 30	48 70	48 B0				

For Radio On/OF unknow : 4B 05

Radio turnknob

48 06 Push 48 46 Push More 1 Second 48 86 Release

32 n0 Rotate Left 32 n1 Rotate Right

n is between 1,9. It is the step related with the rotation speed (message optimization)

Messages to Navigation / Video (3BH)

Nav turnknob

48 05 Push 48 45 Push More 1 Second 48 85 Release

49 0n Rotate Left 49 8n Rotate Right

n is between 1,9. It is the step related with the rotation speed (message optimization)

48 1A 48 1B 48 1C 48 1D 48 1^E 48 0C 48 0D 48 0E 48 0F 49 21 49 23 49 A1 49 A3 49 E1 49 E3 49 61 49 63

Broadcast Messages (FFH)

Button '(phone)'

48 08 Push 48 48 Push More 1 Seconde 48 88 Release

Button '(aux Heating timer)'

48 07 Push

Button 'MENU'

48 34 Push 48 74 Push More 1 Seconde 48 B4 Release

Nav Video display areas (When in radio mode)

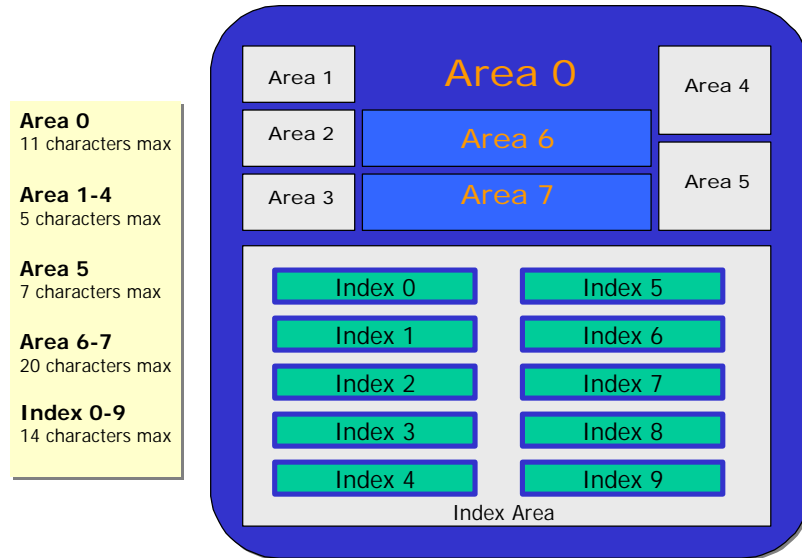

DEVICE ID = FOH

Messages to Navigation / Video (3BH)

Write to Area 0 (Title)

23 62 30 <field value>

The field value can be a text value, or a combination of sub-field values.

23 62 30 est il len° d'index de la zone (30, 31, 32...) ??

20 20
07 20 20 20 20 20
08 43 44 20 31 2D 30 35 20 20

62 est elle la zone haute ?

A Approfondir

Note : the area is not erased before displaying text. It is to the sender to pad the text with spaces.

Write to Zone n

A5 62 01 nn <text>

Zone are 01,02,03,04,05,06,07

Note : Areas are not erased before displaying text. It is to the sender to pad the text with spaces.

Radio to Nav

After switching off the radio

46 0C

Fill the "index" area (the menu displaying CD1, CD 2, CD3, ...)

21 60 00 60 06 <TEXT 1> 06 <TEXT2> 06

21 60 00 43 <TEXT 3> 06 06 06 <TEXT 4> 06

 07 <TEXT 5> 06 <TEXT 6> 06 06

Field

Tag

05 Previous Field ??

06 Next Field

07 Next +1 field ??

08 Next +2 field ??

21 60 00 60 ← 60 could be the global index area ?

Index screen is structured as following (it's a menu) :

0 @	5 E
1 A CD1	6 F CD4
2 B CD2	7 G CD5
3 C CD3	8 H CD6
4 D	9 I

Set Text Index n

21 60 00 nn <text>

Index	nn	Index	nn
0	40	5	45
1	41	6	46
2	42	7	47
3	43	8	48
4	44	9	49

Text is 14 chars max.

Refresh the index area

68 06 3B A5 60 01 00

A5 60 01 00

NAV TO RADIO

3B 06 68

31 60 00 nn

where nn is

Index	Push	Release	Index	Push	Release
0	00	40	5	05	45
1	01 (CD 1)	41	6	06 (CD 4)	46
2	02 (CD 2)	42	7	07 (CD 5)	47
3	03 (CD 3)	43	8	08 (CD 6)	48
4	04	44	9	09	49

Note that index 1,2,3 and 6,7,8 do the radio asking a CD change.

Après

46 02 Come back to the main menu ?

46 0C : Come back to the On board Computer screen ?

```
Source Device      : Radio
Destination Device : Nav Video
Data - - - - -
21 60 00 20
! ` .
Full Packet - - - - -
68 06 3B 21 60 00 20 34
```

Messages to Instrument Kombi Electronics - IKE (80H)

Display CD title in the OBC text bar

```
Source Device      : Radio
Destination Device : IKE
Data Len (Checksum): (1)
Data - - - - -
23 62 30 07 20 20 20 20 20 08 43 44 20 32 2D 30 34 20 20 BC 20
# b 0 . . . C D 2 - 0 4 .
Full Packet - - - - -
68 17 80 23 62 30 07 20 20 20 20 08 43 44 20 32 2D 30 34 20 20 BC 20 01
-----
Special characters : BC = " ▶ "
```

Messages to CD Player (18H)

Poll CD Player

01

Request Current CD and Track Status

38 00 00

Stop Playing

38 01 00

Start Playing

38 03 00

Fast Scan

38 04 nn

Where nn is :

00 Forward
01 Backward

Change CD

38 06 nn

Where nn is the CD number to load (usually between 01,06)

Scan Intro Mode

38 07 nn

Where nn is :

01 Scan mode ON
00 Scan mode OFF

Random Mode

38 08 nn

Where nn is :

01 Random mode ON
00 Random mode OFF

Change Track

38 0A nn

Where nn is :

00 Next track
01 Previous track

CD PLAYER Messages

DEVICE ID = 18H

CD Player behaviour

When the I-Bus wakes up, the CD player starts to announce it-self ("02 01" msg) every 30 secondes until the radio poll ("01"). At the first poll, the CD will send a poll response ("02 00"), then will respond to each next poll (every 30 secondes).

If the CD doesn't respond to the poll, the radio considers that there is no CD Player (or not anymore).

Broadcast Messages (FFH)

Poll Response

02 00

Announce

02 01

Messages to Radio (68H)

- dd is the disk index (usually between 01,06).
- tt is the track index.

CD and Track Status Not Playing Response

39 00 02 00 3F 00 dd tt

CD and Track Status Playing Response

39 00 09 00 3F 00 dd tt

Track Start Playing

39 02 09 00 3F 00 dd tt

CD Status Scan Forward

39 03 09 00 3F 00 dd tt

CD Status Scan Backward

39 04 09 00 3F 00 dd tt

Track End Playing

39 07 09 00 3F 00 dd tt

CD Seeking

39 08 09 00 3F 00 dd tt

Navigation / Vidéo module Messages

DEVICE ID = 3BH

Messages to IKE (80H)

OBC Parameters Get/Reset

41 nn cc <Text>

- nn is the parameter identifier.

- cc is the command :

01 Get Value
10 Reset Value

See the OBC parameter table for "nn" value.

3B 04 F0 4F 00 : Switch off nav screen

3B 04 F0 4F 00 : Switch off

```
Source Device      : Nav Video
Destination Device : IKE
Data - - - - -
15 01 04 80 4A
. . . . . J
Full Packet - - - - -
3B 07 80 15 01 04 80 4A 66
-----
```

```
Source Device      : IKE
Destination Device : Light Ctrl
Data - - - - -
15 01 04 80 4A
. . . . . J
Full Packet - - - - -
80 07 BF 15 01 04 80 4A E2
-----
```

```
Source Device      : Nav Video
Destination Device : IKE
Data - - - - -
15 06 04 80 4A
. . . . . J
Full Packet - - - - -
3B 07 80 15 06 04 80 4A 61
-----
```

```
Source Device      : IKE
Destination Device : Light Ctrl
Data - - - - -
15 06 04 80 4A
. . . . . J
```

Full Packet - - - - -
80 07 BF 15 06 04 80 4A E5

00 German

01,02,05 TIME GB

03 ORA Esp ?

04 HORA IT ?

06 FR HEURE

TEL

C8 04 E7 2C 11 : Display the phone symbol

Source device ID is 7F, but this message (called SPTI) was sent by navigation system.

It have the following format:

7F 14 C8 A2 - src, len, destination and message type.

00 00 - constant

52 33 19 40 - Y coordinate in BCD format.

00 13 11 51 70 - X coordinate in BCD format.

X can vary from 0° to 180°, so the storage is one byte bigger.

coordinate sign is stored in the lowest nibble.

00 00 00 - constant

11 00 - current time in BCD format, (hh:mm, 24h format)

00 00 - constant

0B - XOR checksum